



Image shown may not reflect actual engine

## CATERPILLAR ENGINE SPECIFICATIONS

---

### I-6, 4-Stroke-Cycle Diesel

Bore.....	130.0 mm (5.12 in)
Stroke.....	140.0 mm (5.51 in)
Displacement.....	11.1 L (677.36 in <sup>3</sup> )
Aspiration.....	Turbocharged Aftercooled
Compression Ratio.....	17.2:1
Rotation (from flywheel end).....	Counterclockwise
Weight, Net Dry (approximate kg, lb).....	930 kg, 2050 lb

## FEATURES

---

### Emissions

Meets Tier 3, Stage IIIA emission requirements. Tier 3 refers to EPA (U.S.) standards. Stage IIIA refers to European standards.

### Worldwide Supplier Capability

Caterpillar

- Casts engine blocks, heads, and cylinder liners
- Machines critical components
- Assembles complete engine
- Factory-designed systems built at Caterpillar ISO 9001:2000 certified facilities
- Ownership of these manufacturing processes enables Caterpillar to produce high quality, dependable product.

### Testing

Prototype testing on every model:

- proves computer design
- verifies system torsional stability
- functionality tests every model

Every Caterpillar engine is dynamometer tested under full load to ensure proper engine performance.

### Full Range of Attachments

Wide range of bolt-on system expansion attachments, factory designed and tested.

### Unmatched Product Support Offered Through Worldwide Caterpillar Dealer Network

More than 1,500 dealer outlets  
Caterpillar factory-trained dealer technicians service every aspect of your industrial engine  
99.7% of parts orders filled within 24 hours worldwide  
Caterpillar parts and labor warranty  
Preventive maintenance agreements available for repair before failure options

Scheduled Oil Sampling program matches your oil sample against Caterpillar set standards to determine:

- internal engine component condition
- presence of unwanted fluids
- presence of combustion by-products

### Web Site

For all your industrial power requirements, visit [www.cat-industrial.com](http://www.cat-industrial.com).

**STANDARD ENGINE EQUIPMENT**

---

**Air Inlet System**

Air to air aftercooled (ATAAC)  
Turbocharged

**Control System**

Electronic governing, PTO speed control  
Programmable ratings  
Cold mode start strategy  
Automatic altitude compensation  
Power compensation for fuel temperature  
Programmable low and high idle and total engine limit  
Electronic diagnostics and fault logging  
Engine monitoring system  
J1939 Broadcast (diagnostic and engine status)  
ADEM™ A4

**Cooling System**

Thermostats and housing, vertical outlet  
Jacket water pump, centrifugal  
Water pump, inlet

**Exhaust System**

Exhaust manifold, dry  
Optional exhaust outlet

**Flywheels and Flywheel Housing**

SAE No. 1 Flywheel housing

**Fuel System**

MEUI injection  
Fuel filter, secondary (2 micron high performance)  
Fuel transfer pump  
Fuel priming pump  
ACERT™ Technology

**Lube System**

Crankcase breather  
Oil cooler  
Oil filler  
Oil filter  
Oil pan front sump  
Oil dipstick  
Oil pump (gear driven)

**General**

Paint, Caterpillar Yellow  
Vibration damper  
Lifting eyes

**PERFORMANCE CURVES**

IND - B - DM7691-01

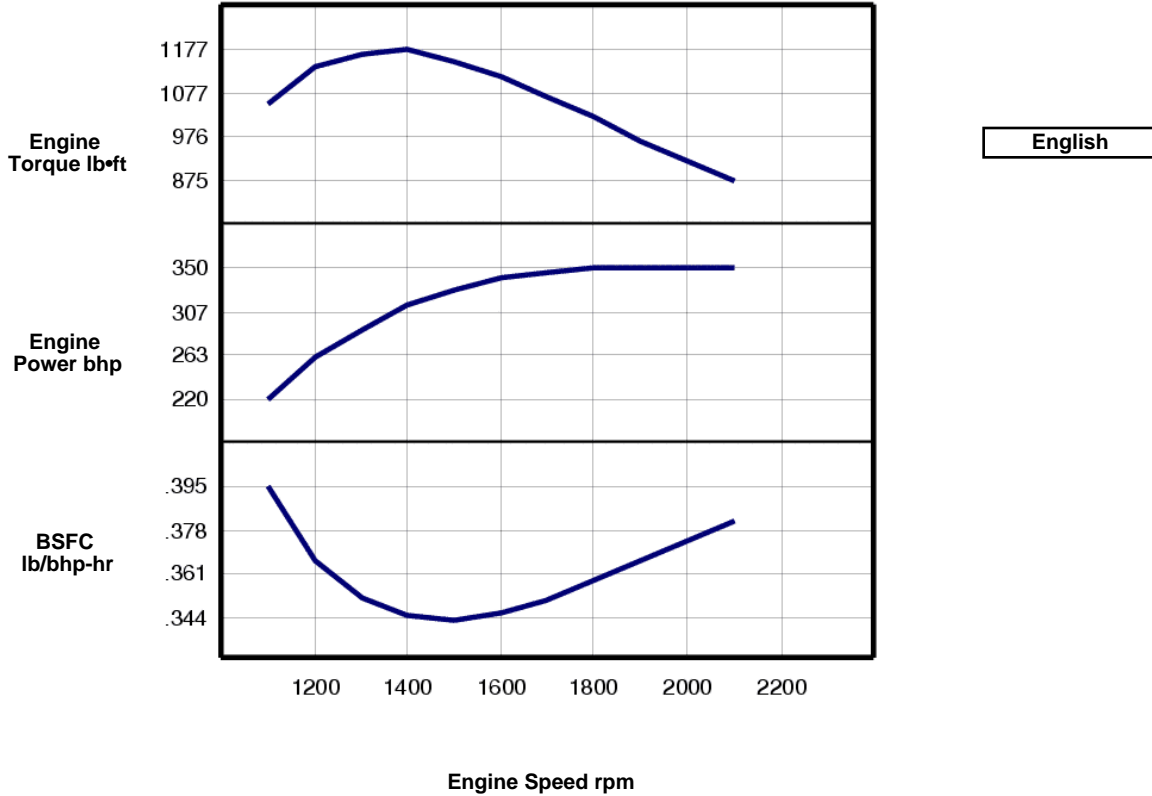

Engine Speed rpm	Engine Power bhp	Engine Torque lb•ft	BSFC lb/bhp-hr	Fuel Rate gal/hr
2100	350	875	.382	19.1
2000	350	919	.374	18.7
1900	350	968	.366	18.3
1800	350	1022	.358	17.9
1700	346	1069	.351	17.4
1600	339	1114	.345	16.7
1500	329	1151	.343	16.1
1400	314	1177	.345	15.5
1300	288	1165	.351	14.5
1200	260	1139	.366	13.6
1100	220	1050	.395	12.4

**RATINGS AND CONDITIONS**

**IND - B** For service where power and/or speed are cyclic (time at full load not to exceed 80%).

**Engine Performance Diesel Engines** — 7 liter and higher All rating conditions are based on SAE J1995, inlet air standard conditions of 99 kPa (29.31 in. Hg) dry barometer and 25°C (77°F) temperature. Performance measured using a standard fuel with fuel gravity of 35° API having a lower heating value of 42,780 kJ/kg (18,390 btu/lb) when used at 29° C (84.2° F) with a density of 838.9 g/L.

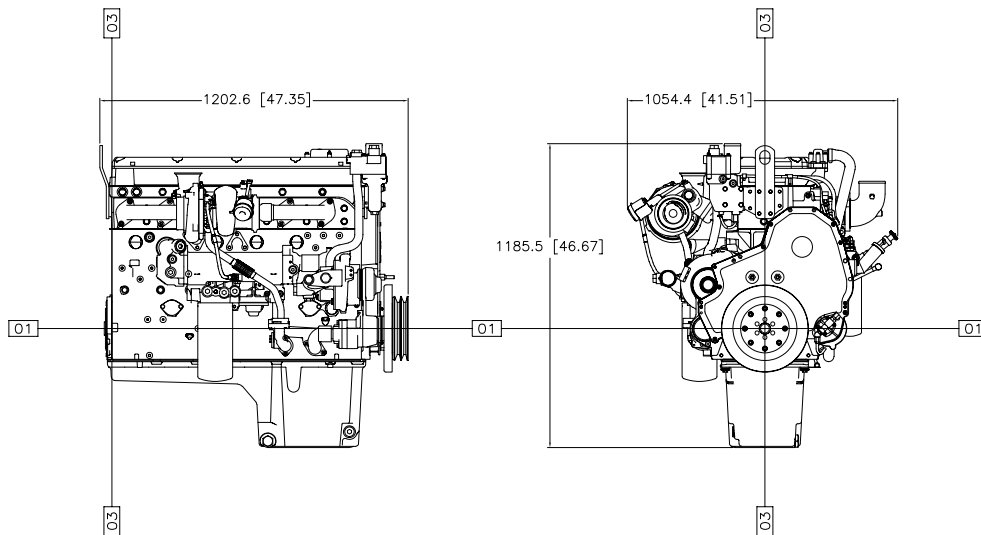

<b>Engine Dimensions</b>	
(1) Length	47.35 in
(2) Width	41.51 in
(3) Height	46.67 in

Note: Do not use for installation design. See general dimension drawings for detail (Drawing # 2588858 ).

Performance Number: DM7691-01

Feature Code: C11DI01

Materials and specifications are subject to change without notice.

6757224

© 2006 Caterpillar

All rights reserved.

The International System of Units (SI) is used in this publication.

CAT, CATERPILLAR, their respective logos and "Caterpillar Yellow," as well as corporate and product identity used herein, are trademarks of Caterpillar and may not be used without permission.