

HH-80 Technical Specifications

Production Curve

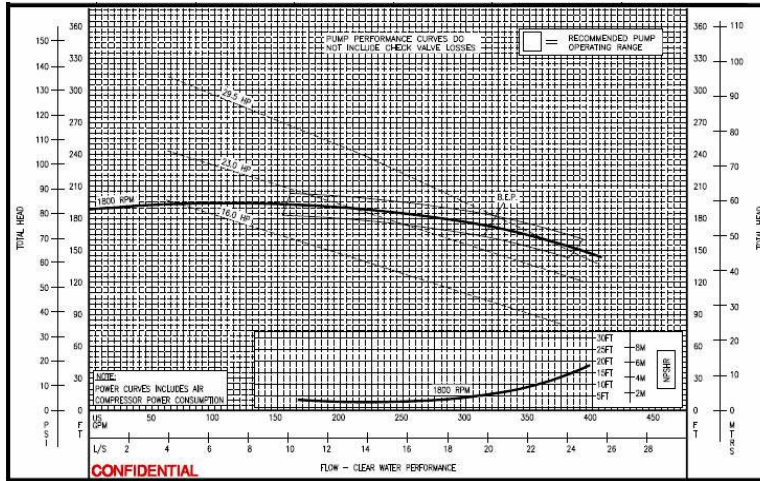

Performance Specs

STANDARD 3 VANE IMPELLER

Maximum Operating Speed:	1760 rpm
Maximum Head:	180 ft.
Maximum Flow:	380 gpm

Design Details

Pump Designation:	HH-80
Pump Description:	Centrifugal end suction pump, single stage, volute type, 3 vane fully open impeller
Solid Handling Size:	1 inch (25mm)
Operating Temperature	MIN: -4°F (-20°C) MAX: +212°F (+100°C)

Dimensions

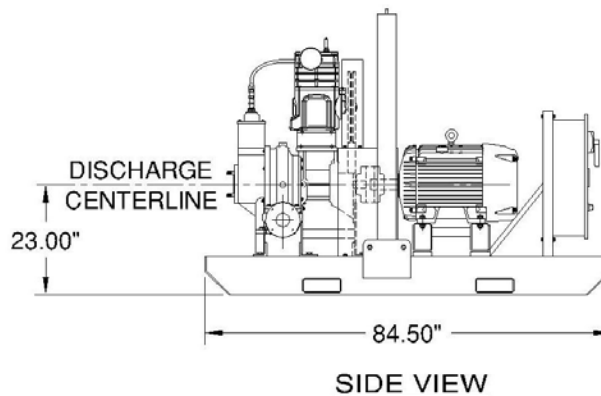
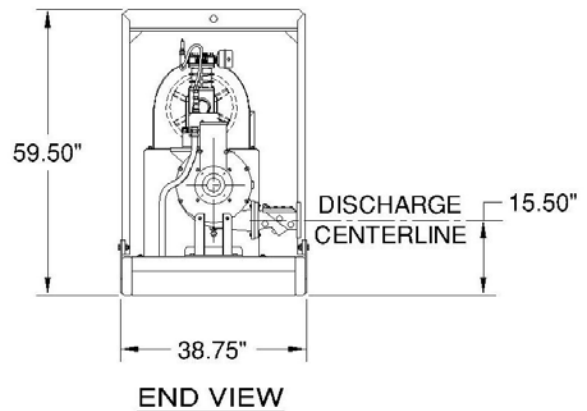

POWER PRIME™ PUMPS

P.O. Box 2248
 Bakersfield CA 93303
 800 647-7246
 661-399-9058
 FAX 661-399-3374
 www.powerprime.com
 sales @ powerprime.com

Power Prime™ is a registered trademark of Western Oilfields Supply Company. Features and Specifications are subject to change without notice.