

## HH-80 Technical Specifications

### Production Curve

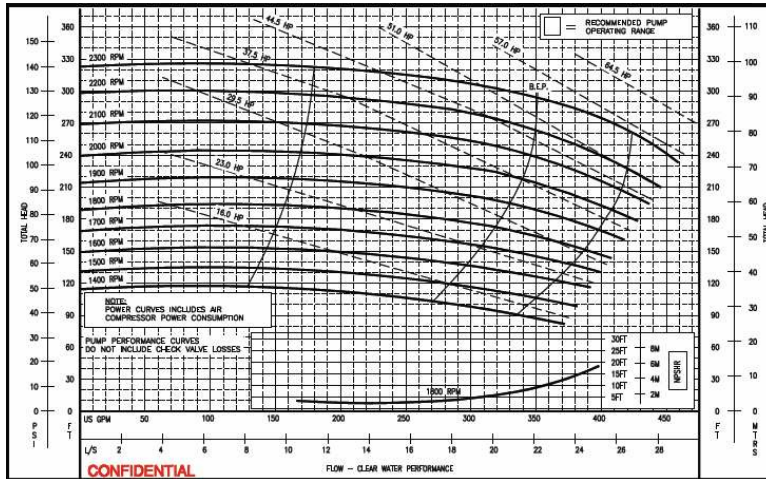

### Performance Specs

#### STANDARD 3 VANE OPEN IMPELLER

Minimum Operating Speed:	1400 rpm
Maximum Operating Speed:	2300 rpm
Maximum Head:	320 ft.
Maximum Flow:	450 gpm

### Design Details

<b>Pump Designation:</b>	HH-80
<b>Pump Description:</b>	Centrifugal end suction pump, single stage, volute type, 3 vane fully open impeller
<b>Solid Handling Size:</b>	1 inch (25mm)
<b>Operating Temperature</b>	MIN: -4°F (-20°C) MAX: +212°F (+100°C)

### Dimensions

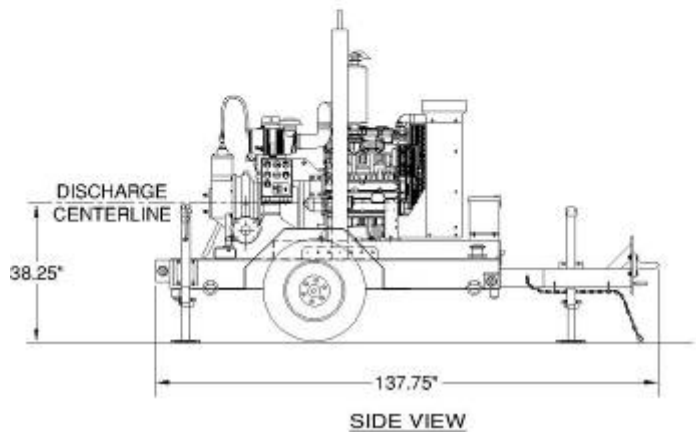
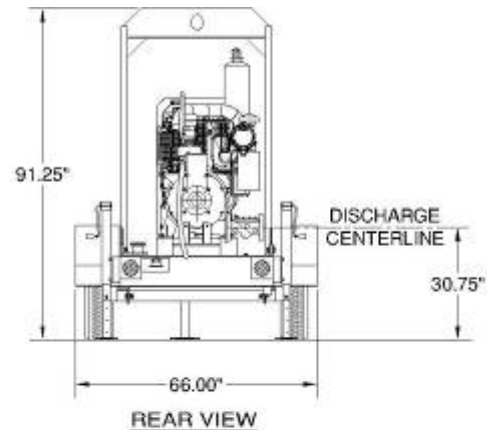

#### POWER PRIME™ PUMPS

P.O. Box 2248  
Bakersfield CA 93303  
800 647-7246  
661-399-9058  
FAX 661•399-3374  
www.powerprime.com  
sales @ powerprime.com

Power Prime™ is a registered trademark of Western Oilfields Supply Company. Features and Specifications are subject to change without notice.